



ARISTO ANANDAM, NR. MALABAR EXOTICA, B/H NIRMA UNIVERSITY, OFF S.G.HIGHWAY, AHMEDABAD.

☎ 8511026666 | 8511036666

✉ info@aristobuilder.com

🌐 aristobuilder.com

RERA : PR/GJ/AHMEDABAD/AHMEDABAD CITY/AUDA/MAA10099/280422 / WWW.GUJRERA.GUJARAT.GOV.IN

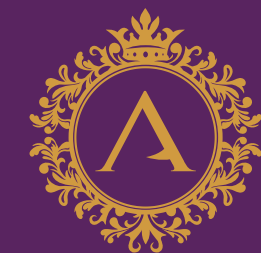

ARISTO  
— ANANDAM —

3 BHK *upscale*  
LIVING & SHOPS

*upscale*

—  
PREMIUM LIFESTYLE THAT DEFINES AN

*upscale life*



ARISTO  
— ANANDAM —

A sparkling experience of wholesome happiness awaits you and your family at Aristo Anandam.

Introducing the luxurious Bliss, where an apartment is more than just a home; it's a lifestyle with an amicable community to foster it. Stunning apartments, penthouse with a number of perfectly planned, carefully integrated lifestyle amenities, all set to make every day exciting.





AN AMBIENCE THAT MAKES AN

*upscale* **life**





THE GRACE  
OF STRUCTURE MAKES AN  
*upscale* life

- 4 BHK PENTHOUSE
- 3 BHK APARTMENTS
- PRIVATE FOYER
- MAXIMUM UTILIZATION OF SPACE
- SPACIOUS BALCONY
- PREMIUM FACING FLATS
- VASTU COMPLIANT





RHYTHM OF RELAXATION MAKES AN

*upscale* life



BOX CRICKET



MULTI PURPOSE HALL



JOGGING TRACK



GYM



24 X 7 SECURITY



RAIN WATER HARVESTING



KID'S PLAY AREA



YOGA DECK



EVENT LAWN



INDOOR GAME



FIRE SYSTEM



E- CAR CHARGING FACILITIES



ENTRY / EXIT



24 HRS WATER



POWER BACKUP



ELEVATOR



SMART SOCIETY



ALLOCATE CAR PARKING



CCTV CAMERA



TODDLERS AREA



GAZEBO



DROP OFF ZONE



SOLAR SYSTEM



MULTI PURPOSE COURT



SENIOR CITIZEN AREA



NO VEHICLE ZONE AREA



SEWAGE TREATMENT PLANT



2 LEVEL BASEMENT



COMMON AREA WIFI CONNECTED



GAS LINE



THE GOOD PLANING  
MAKES AN  
*upscale* future

25 SHOPS | 208 APARTMENTS | 8 PENTHOUSE | 30+ AMENITIES



ARISTO ANANDAM

GROUND FLOOR PLAN





FIRST & TYPICAL FLOOR

PENTHOUSE FLOOR

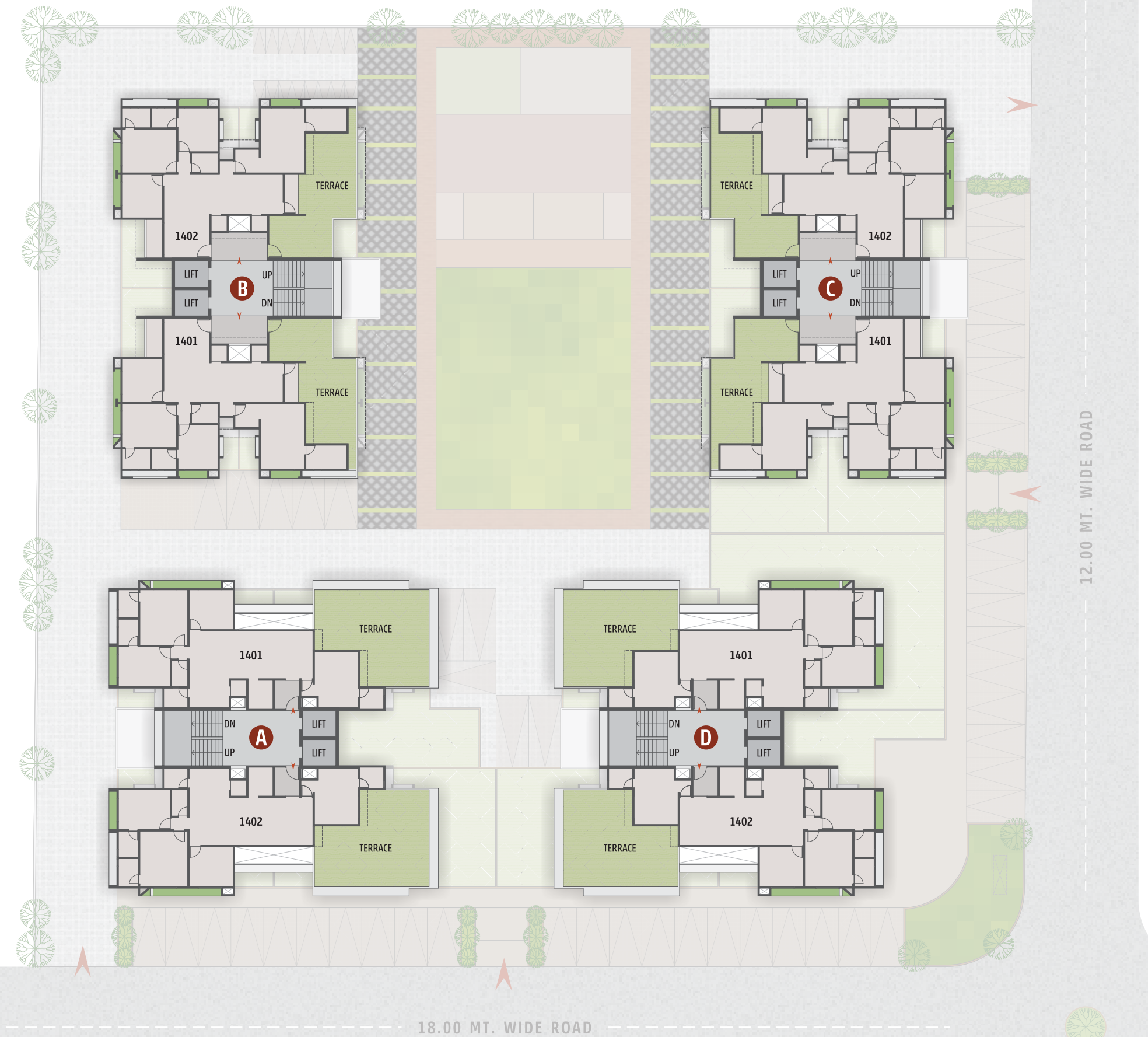



3 BHK - UNIT A

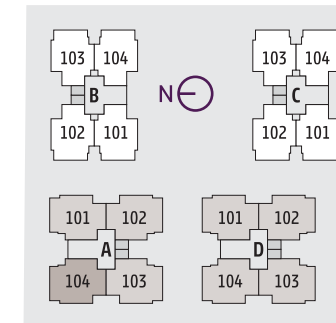



3 BHK - UNIT B

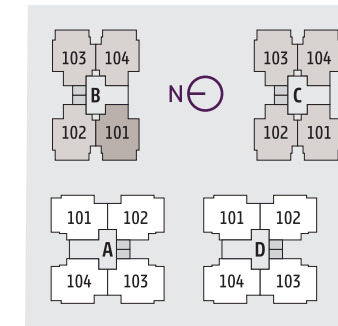



PENTHOUSE UNIT-A - 4 BHK

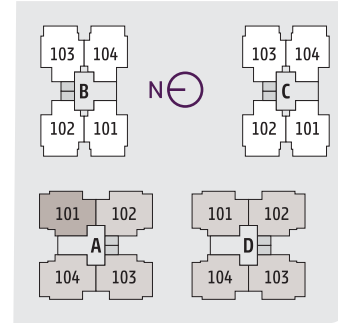

PENTHOUSE UNIT-B - 4 BHK

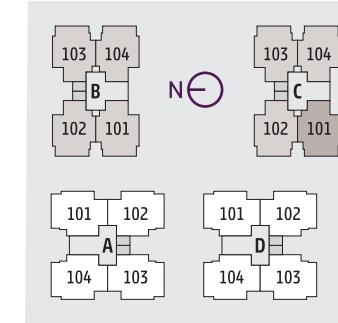









THE JOY OF  
BEST LIVING MAKES AN  
*upscale* life







## SPECIFICATIONS

### STRUCTURE

- EARTHQUAKE RESISTANT R.C.C. FRAME STRUCTURE.

### DOORS & WINDOWS

- DECORATIVE BOTH SIDE LAMINATE FINISHED MAIN DOOR WITH WOODEN FRAME.
- OTHER DOORS ARE FLUSH DOOR WITH WOODEN FRAME.
- ANODIZED COATED ALUMINUM SLIDING WINDOW WITH STONE SILL.

### ELECTRIFICATION

- CONCEALED COPPER WIRING WITH MODULAR SWITCHES & SUFFICIENT NUMBER OF POINTS WITH MCB DISTRIBUTION PANEL, AC & GEYSER POINTS.
- ISI CABLES & ISI SWITCHES

### ELEVATORS

- BELT OPERATED GEARLESS ELEVATOR WITH ARD (Automatic Rescue Device) SYSTEM

### TOILET & PLUMBING

- DESIGNER GLAZED TILES UP TO LINTEL LEVEL.
- PREMIUM QUALITY BATH FITTINGS & SANITARY WARES.

### FLOORING

- VITRIFIED TILES.
- VITRIFIED RUSTIC TILES IN BALCONY.
- CHINA MOSAIC FOR HEAT REFLECTION & WATER PROOFING TREATMENT IN TERRACE.

### KITCHEN

- GRANITE TOP PLATFORM WITH S.S. SINK.
- DESIGNER GLAZED TILES DADO UP TO LINTEL LEVEL.







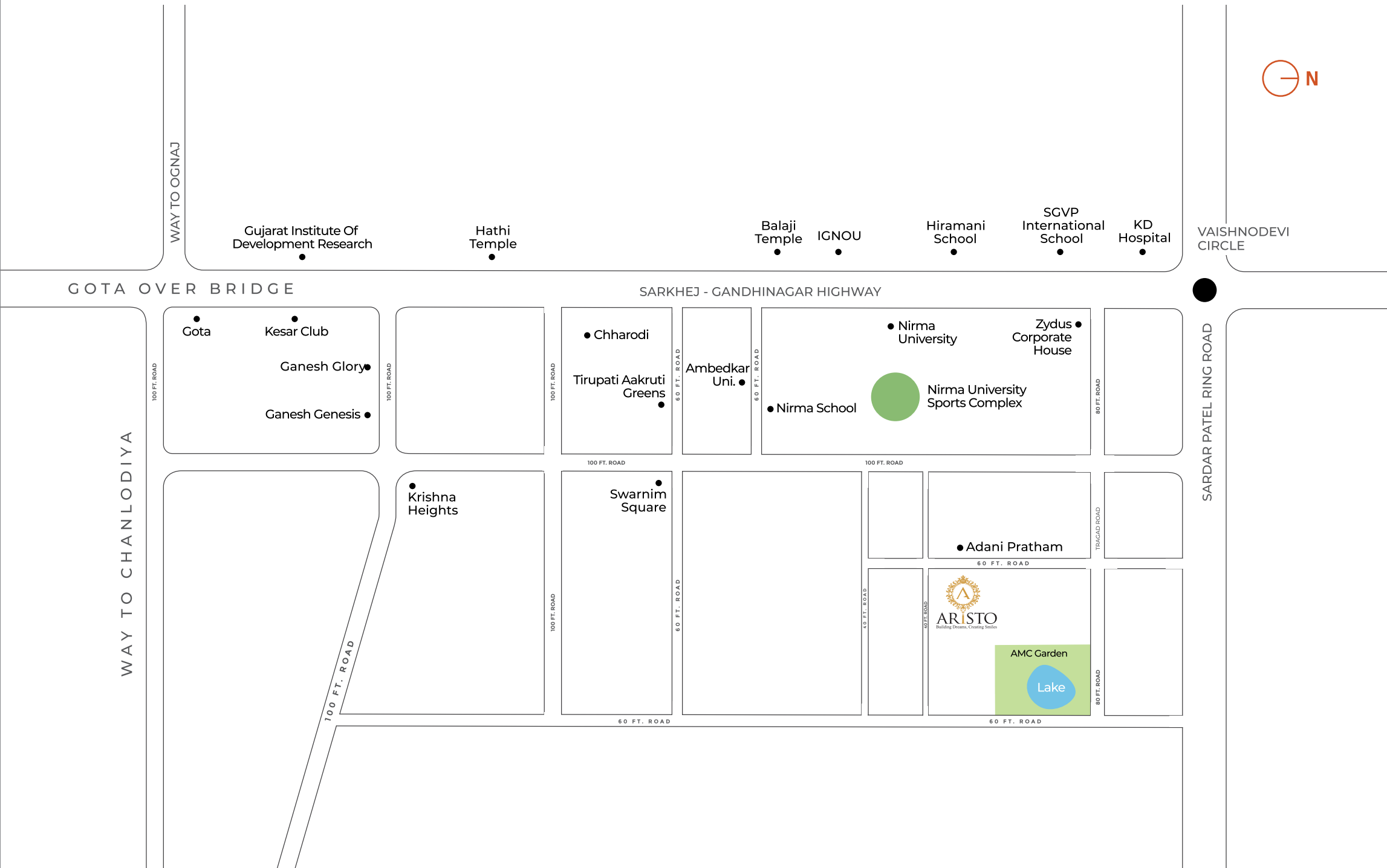

### WALL FINISH

- INTERNAL SINGLE COAT MALA PLASTER WITH PUTTY FINISH.
- EXTERNAL DOUBLE COAT TEXTURE WITH ACRYLIC PAINT.



A GREAT  
CONNECTIVITY MAKES  
*upscale* life



-  2 MIN\_\_\_ FOR S G HIGHWAY
-  2 MIN\_\_\_ FOR S P RING ROAD
-  3 MIN\_\_\_ FOR NIRMA COLLEGE
-  5 MIN\_\_\_ FOR SARDARDHAM
-  5 MIN\_\_\_ FOR NIRMA SCHOOL
-  5 MIN\_\_\_ FOR KD HOSPITAL
-  5 MIN\_\_\_ FOR VAISHNODEVI
-  5 MIN\_\_\_ FOR SGVP HOSPITAL
-  5 MIN\_\_\_ FOR HIRAMANI SCHOOL



LOCATION QR

RULES & REGULATIONS • Stamp Duty, Registration Charges, Legal Documentation Charges, GST, Maintenance Deposit, Torrent Charges and any other charges shall be borne by buyer separately. • Any Additional charges of duties levied by government / local authority during or after the completion of the project will be borne by the buyer. • Internal changes shall be done with prior permission and shall be charged in advance. • Changes in external elevation shall not be permitted. • All rights reserved by the developer for alteration / modification / improvement in specification / changes in dimensions and planning shall be binding to all. • Business practices leading to pollution, causing material damage to the building or members are not allowed in the premises. • Irregular payments may attract interest or lead to cancellation of booking/s.  
DISCLAIMER • This brochure and model are not part of any legal documents. • All dimensions / measurement given are unfinished and approximates. • The photographs & artistic impressions are for references only. Actual building may vary from the representations mentioned in the brochure. • This is not an advertisement within the meaning of RERA. This is not an offer, invitation or commitment of any nature. Receipts are advised to appraise themselves of the necessary and relevant information of the project prior to making any purchase decisions. All the specifications of the flat shall be as per the final agreement between the parties. \* Subject To Ahmedabad Jurisdiction • T&C Applicable