

RATNA BUSINESS HUB-I

THE COMMERCIAL COMPLEX



WHERE IDEA MEETS BUSINESS

When you are doing business you need to look the part too, which is why, a workspace at Ratna Business Hub-I can be a valuable advantage. The location offers great advantages for small, medium and large scale retailers of all market segments

AN EXTRAORDINARY BUSINESS HUB



RATNA BUSINESS HUB-I is designed to offer a global business experience at work: naturally, its location has been picked with care. Standing elegantly and easily accessible by road. with a strategic location and its unique flexible design, your work space at Ratna Business Hub-I would easily rank as the most desirable workspace in Ahmedabad.

A WORKSPACE THAT SIGNALS YOUR STATURE AND SHOWCASE YOUR COMPANY'S IMAGE.

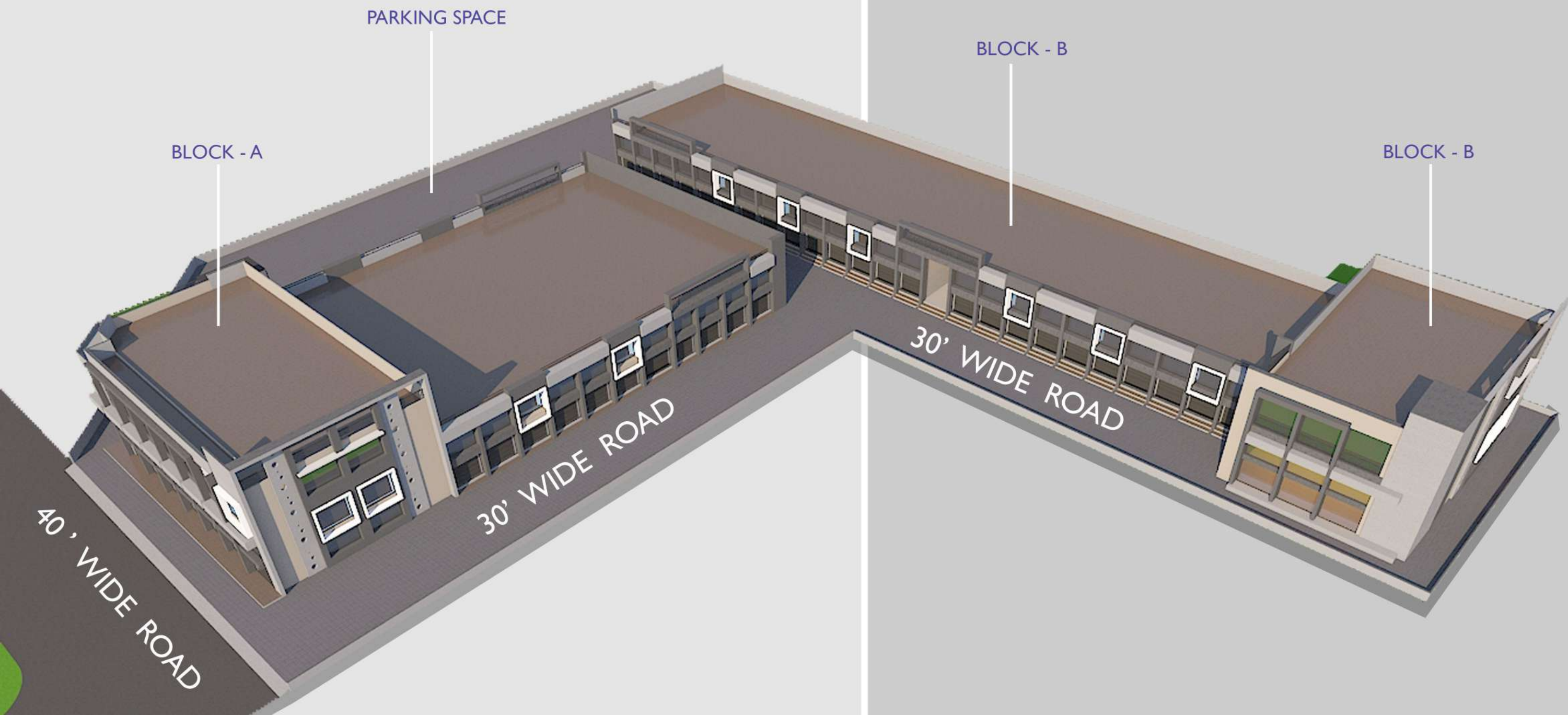

GF 1 TO 30

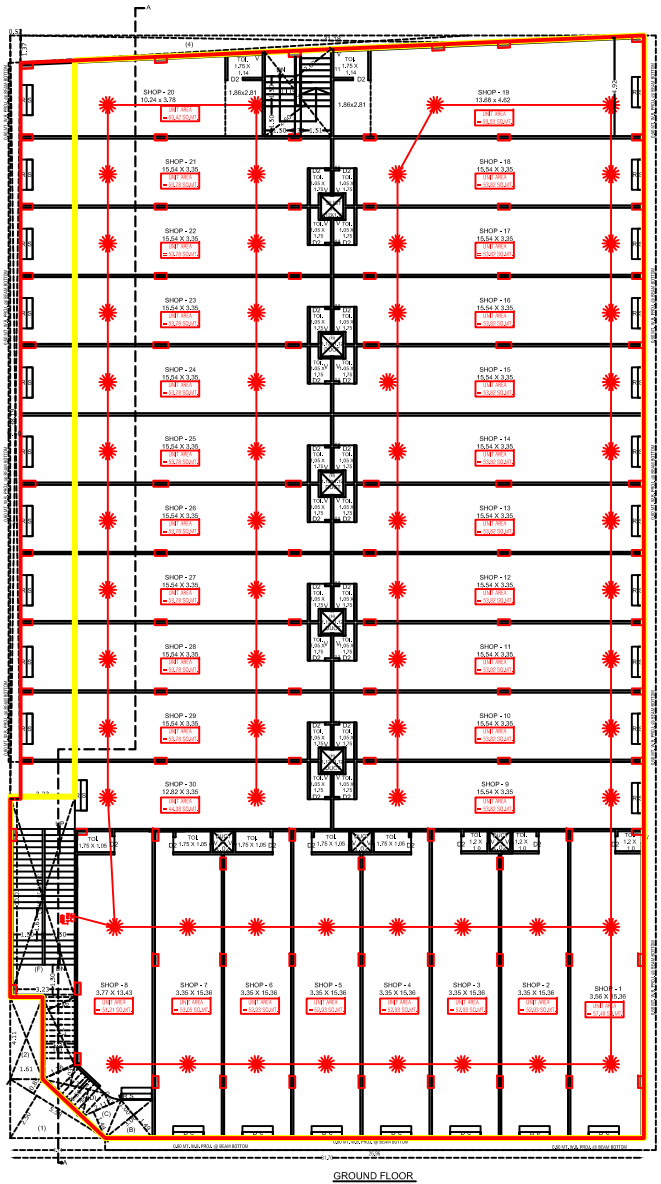

FF 101 TO 108

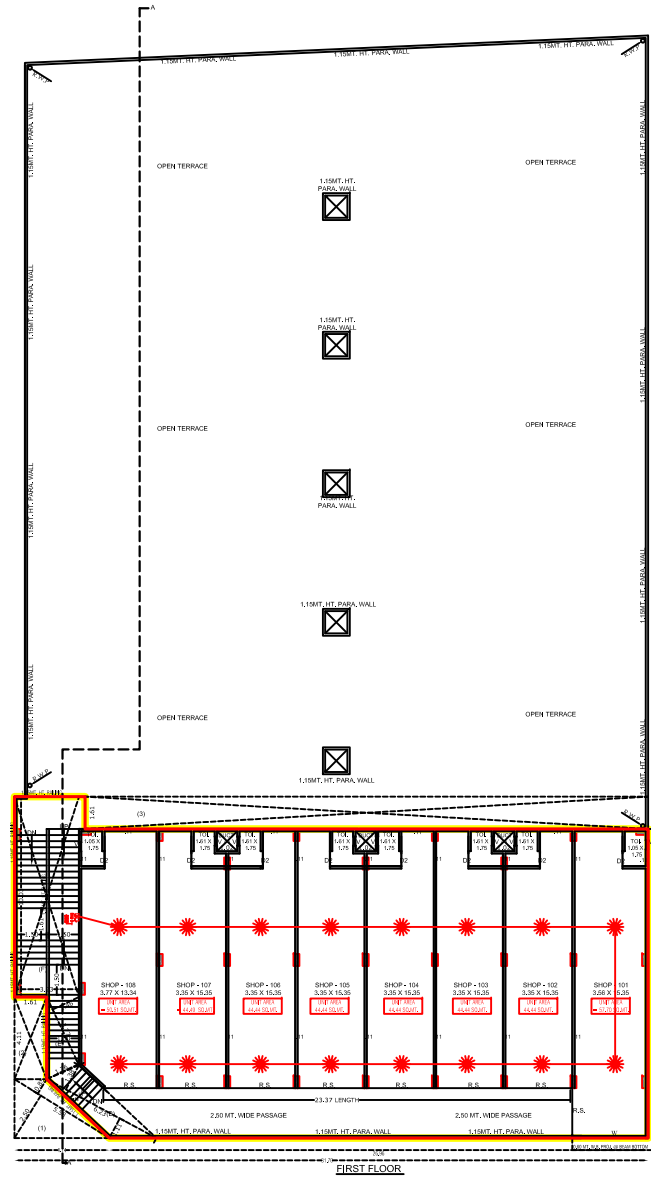

GF 31 TO 56

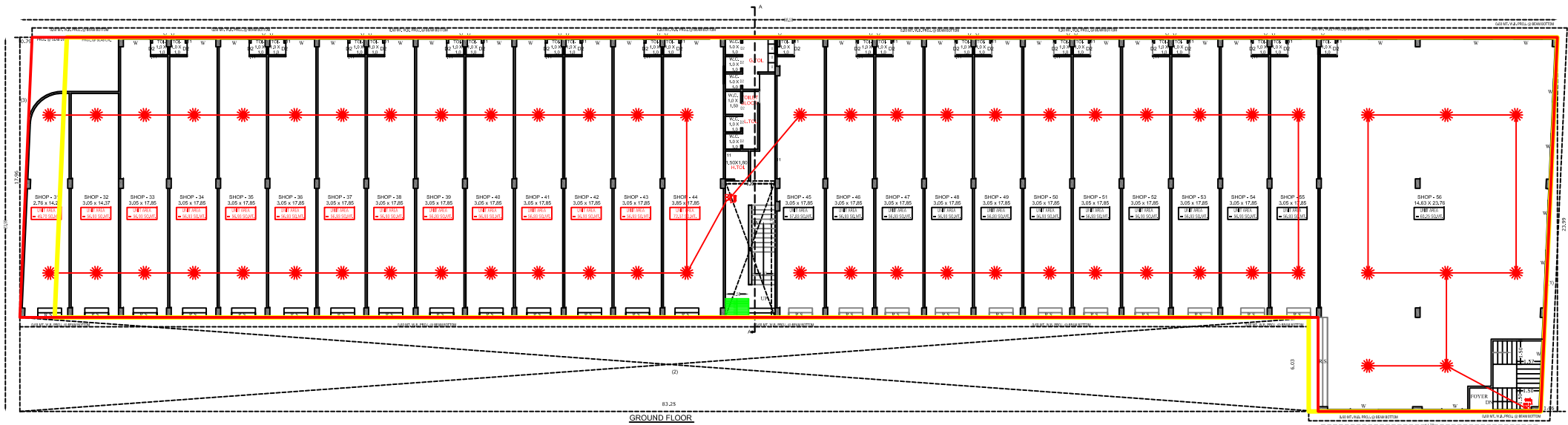

PERFECT BUSINESS HUB FOR MODERN BUSINESS



AMENITIES

-  Fire Safety System
-  Retail & Combo Show Rooms
-  Spacious Work Spaces
-  Well-Attended Lobby
-  Earth-Quake Resistant RCC Design
-  CCTV Cameras
-  High Level Security
-  24 Hours Water Supply
-  Vastu Compliant

SPECIFICATION

STRUCTURE

EARTHQUAKE RESISTANCE R.C.C FRAME STRUCTURE.

FLOORING

POLISH KOTA STONE FLOORING
TILES DADO UP TO LINTEL LEVEL
PAVING IN PARKING

ELECTRIFICATION

BRANDED MODULAR SWITCHES
3 PHASE CONCEALED COPPER WIRING WITH ADEQUATE NUMBER OF POINTS

WINDOWS

ANODIZED ALUMINIUM SLIDING WINDOWS

WALL FINISH

EXTERNAL DOUBLE COTE TIPPANI PLASTER WITH WATER PROOF COLOUR
INTERNAL SMOOTH PLASTER WITH PUTTY FINISH

PLUMBING WORK

STANDARD QUALITY PLUMBING FIXTURE & SANITARY WARE
C.P.V.C PIPES FOR WATER SUPPLY
PERCOLATION WELLS AS PER THE NORMS

PARKING

ALLOTMENT BASEMENT PARKING
CAR AND TWO-WHELLER PARKING ON GROUND FLOOR

SPECIAL FEATURE

C.C.T.V CAMERA WITH 24X7 SECURITY SYSTEM
COMMON POWER BACKUP SYSTEM
FIRE FIGHTING SYSTEM
WIDE APPROACH ROAD

GujRERA Registration Number : ____

GujRERA Website : <https://gujrerar1.gujarat.gov.in/home>



LOCATION

SITE ADDRESS

RATNA BUSINESS HUB-I

NEAR GOPAL PALACE HOTEL, OPP. B.P PETROL PUMP, SANATHAL-CHANGODAR HIGHWAY, NEAR SANATHAL CHOKDI RING ROAD, AHMEDABAD

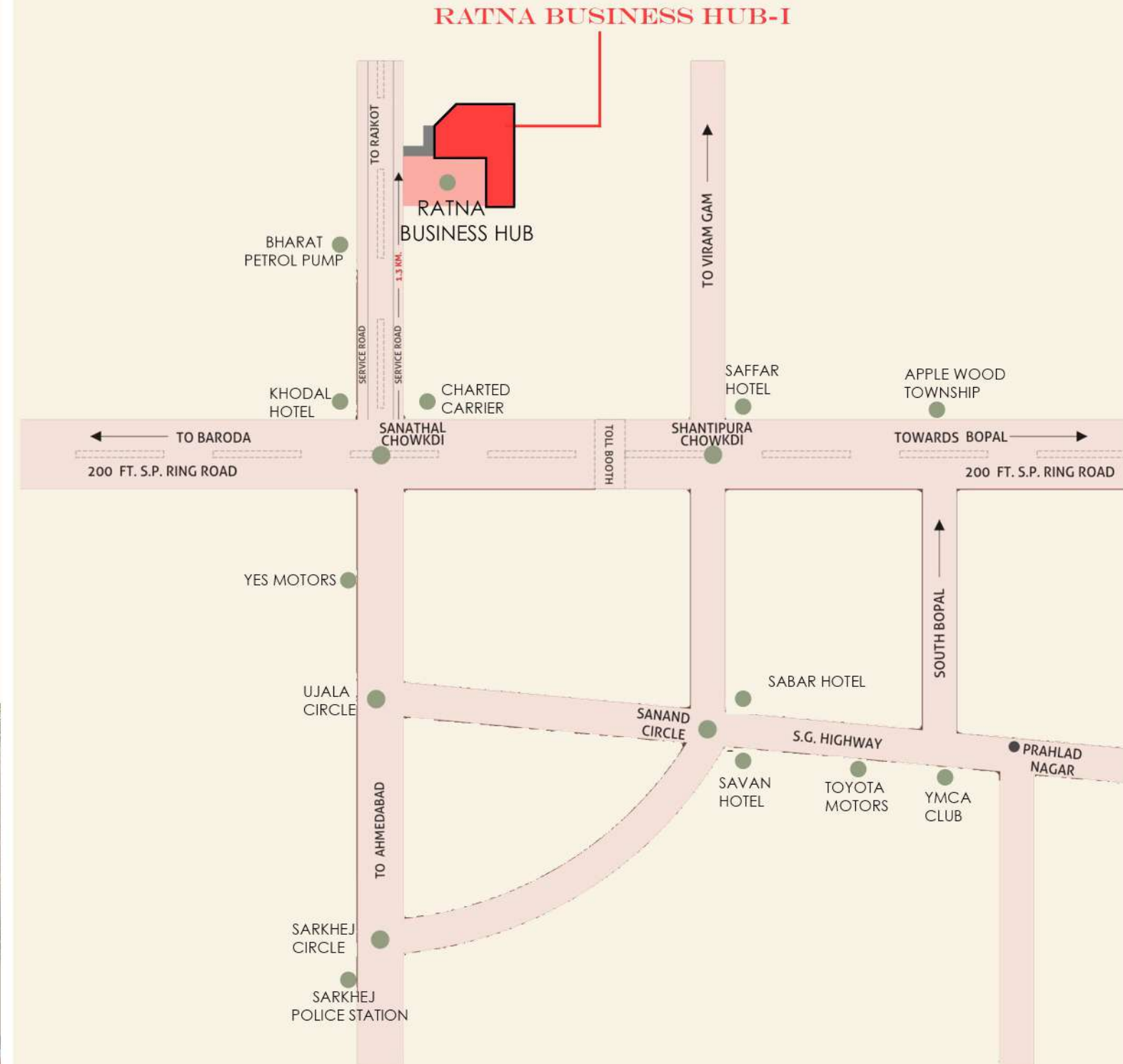

DEVELOPER
RANTODAY DEVELOPER
AHMEDABAD

ARCHITECTS
VARSHA DESIGN CONSULTANT
+91-9227226644

STRUCTURE DESIGN
THE PYRAMID CONSULTANT
+91 9925425608