

Follow US On :  

agspconstruction@gmail.com

Developer :



Enquiries :

90998 34671, 94274 92192, 99983 98471



94260 04671

Site Address: Krishnam Airwings, Behind Green Land Bungalows, Opp. Sarva Square,
Near Water Tank, Behind Cygnus School, Harni, Vadodara.

Terms & Conditions : 1. Registration Charges, Stamp Duty, Service Tax, G.S.T., V.A.T., Corporation or any other State Or Central Government Tax if applicable in future should be borne by the buyers (clients) 2. Possession will be given only after 45 days of settlement of all accounts. 3. Payment schedule must be followed strictly; any delay in the payment shall incur interest penalty at the rate of 18% P.A. on the outstanding amount. 4. In case of cancellation of booking, amount will be refunded only when same property is booked by a new buyer and 25% of booking amount shall be deducted as administration charges before refunding the amount. 5. The developers reserve all the right to change the plan, elevation, specification or any details will be binding to all. 6. In case of delay in water supply, light connection, drainage work by the concerned authority, developers will not be responsible. 7. Change in any structural design & changes in any external facade will not be permitted under any circumstances. 8. Internal changes will only be permitted with prior permission. 9. Outdoor A.C. Units will be fitted as per provision provided in the designated place by the architect. 10. The brochure shall not be treated as legal documents, it is for the purpose of information only. 11. The Images given in the brochure is only for visual depiction and information of the project to help the buyer. 12. All the dimensions given in the brochure are approximate & the same may vary marginally.

Print Events
7779086000

KRISHNAM AIRWINGS

2 & 3 BHK Spacious Flats





ONE
SHE DESERVES



GET HER
THE BEST

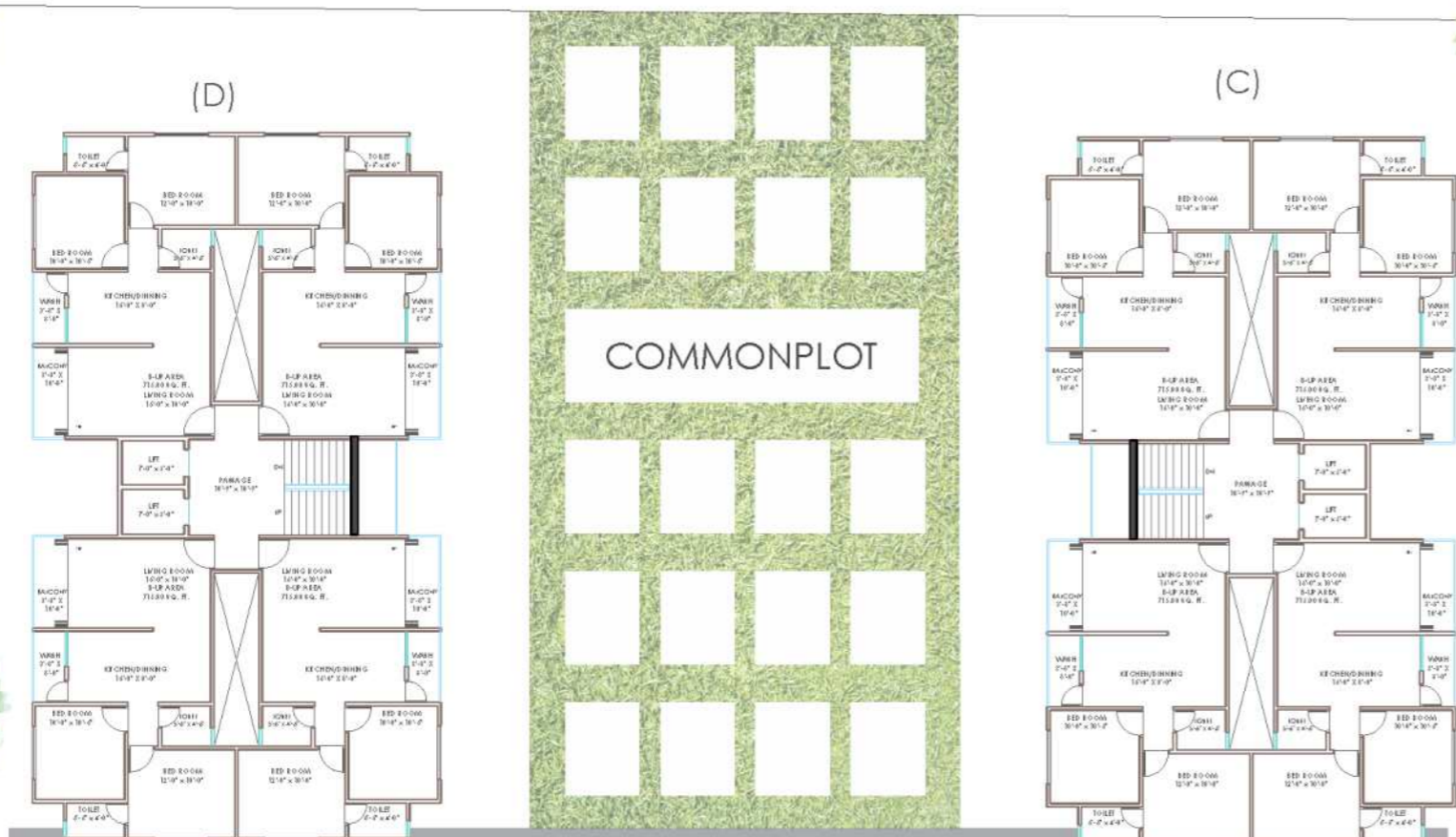

KRISHNAM
AIRWINGS

LAYOUT PLAN



3BHK
TOWER A & B

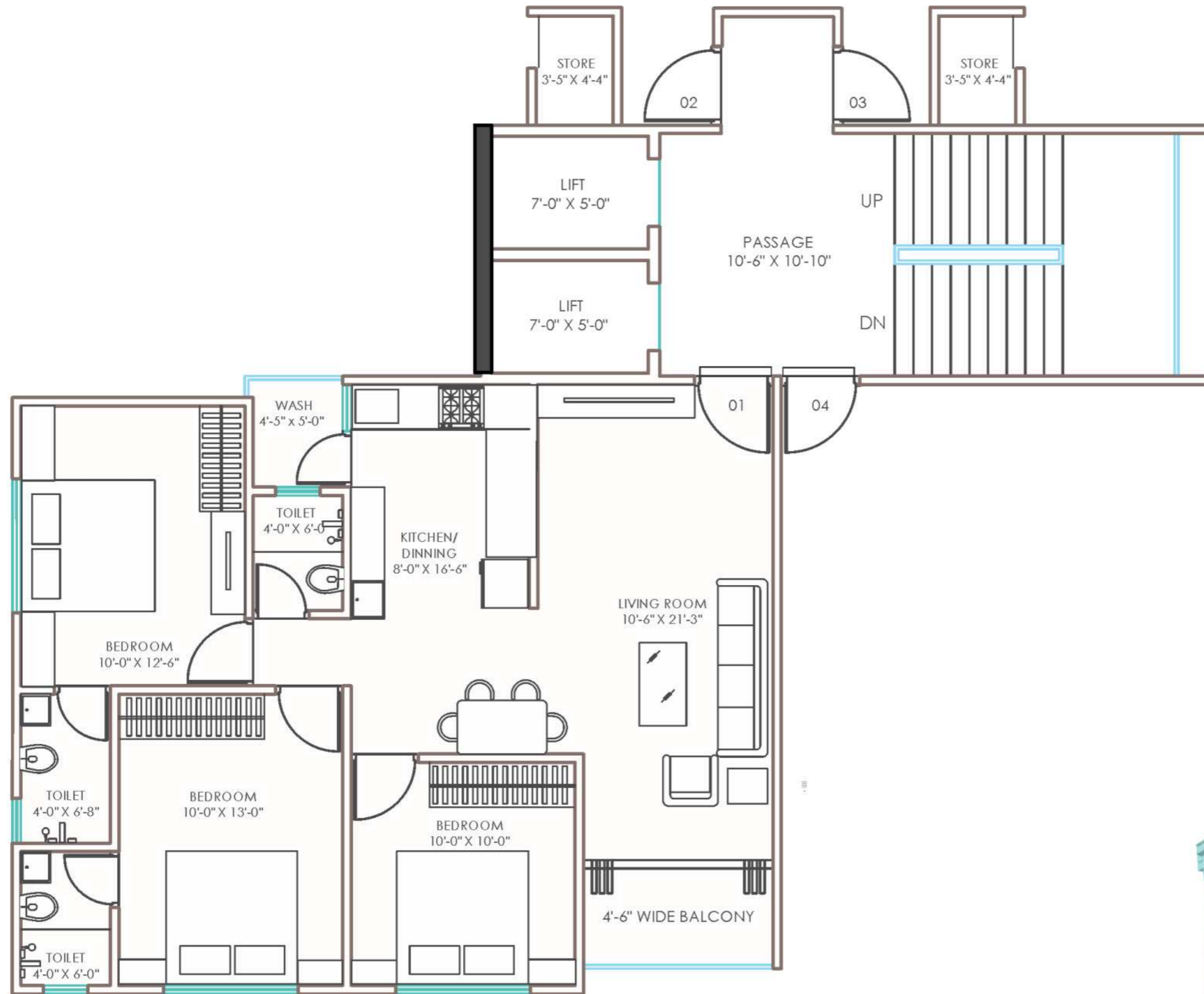
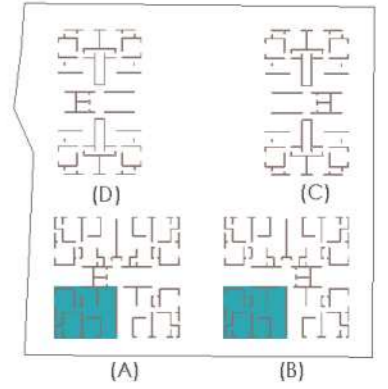

3BHK
TOWER A & B

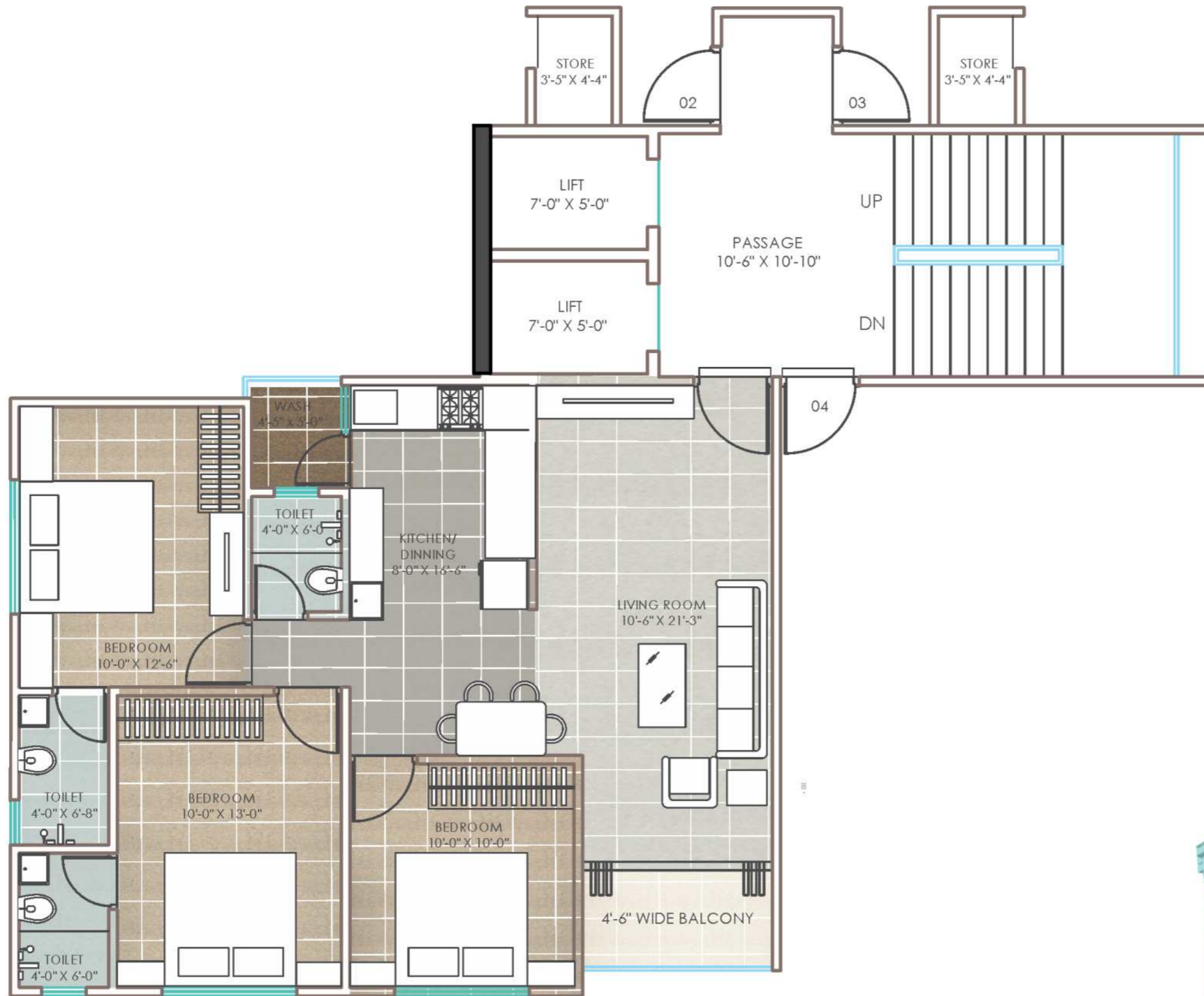
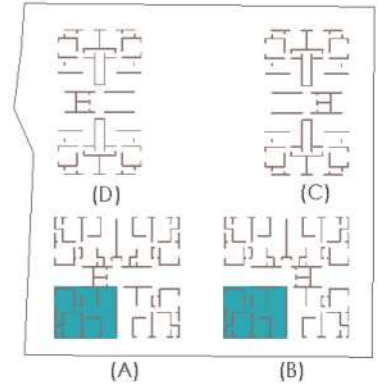



3BHK
TOWER A & B



2BHK
TOWER C & D

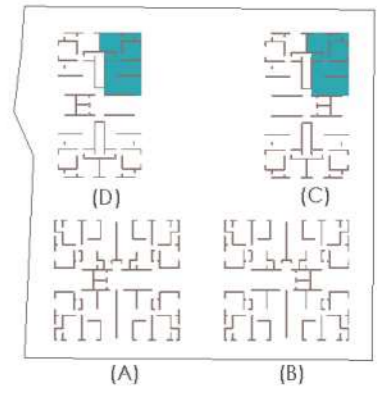
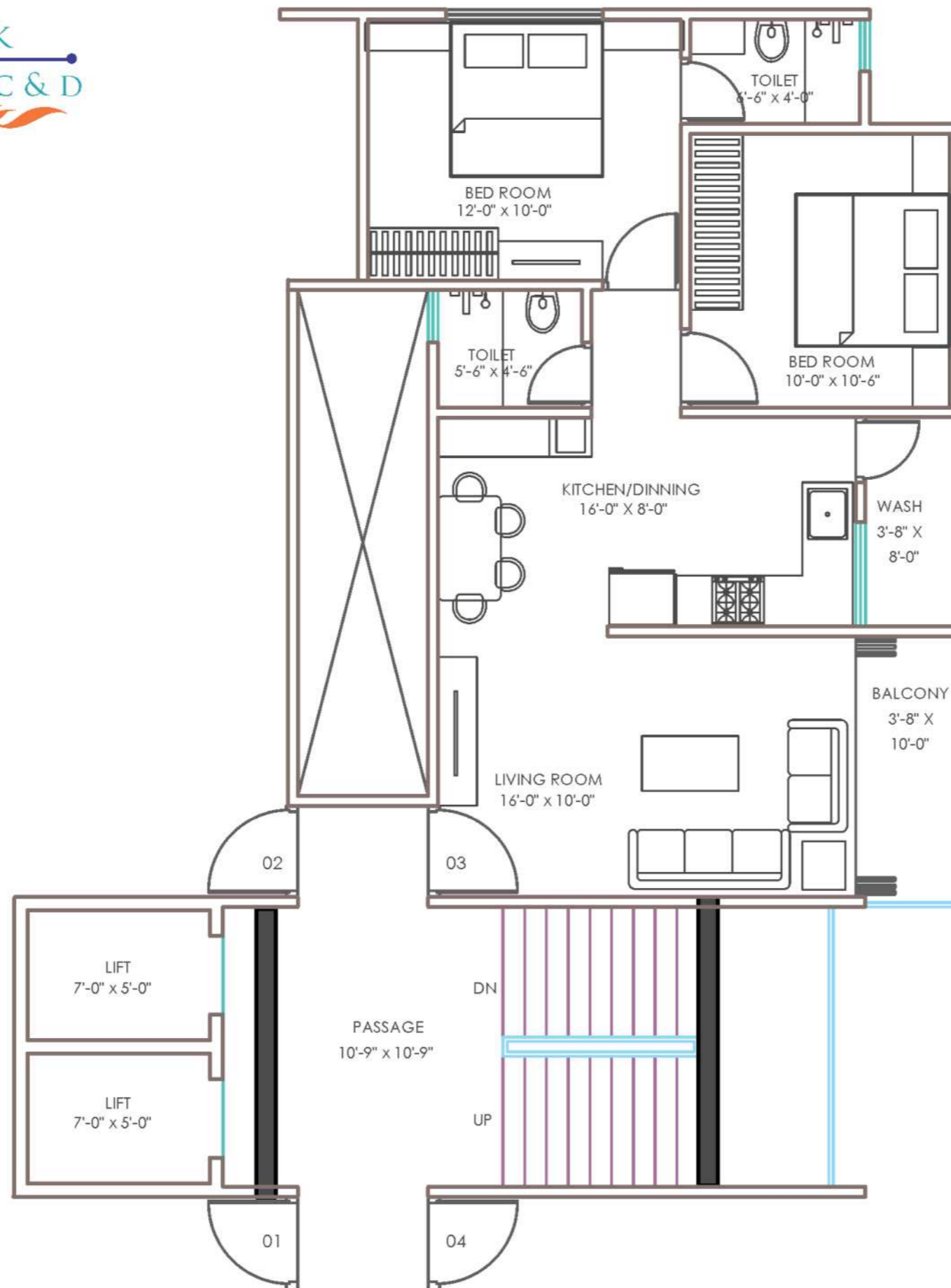



2BHK
TOWER C & D





SPECIFICATIONS



- **Structure:** Earthquake resistant RCC frame structure using superior quality materials as per architectural and structural consultant design.
- **Wall Finish:** Internal walls with smooth plaster finish, good quality putty, External walls with weather proof acrylic paint.
- **Flooring:** 24"x24" vitrified tiles in all rooms with skirting. Epoxy grout filling between tiles in living rooms of flats and penthouses. Granite on steps for external staircase.
- **Kitchen:** Granite platform with stainless steel sink. Designer ceramic tiles upto lintel level. Reverse Osmosis System for hygienic drinking water. A wash/ utility with kota stone and glazed tiles on the walls. The wash area in all the flats and penthouses will undergo waterproofing treatment.
- **Doors and Windows:** Elegant entrance main door; waterproof flush door in all internal rooms. Anodized aluminium section windows with artificial stone frame.
- **Toilets:** Designed with good quality sanitary wares and ceramic tiles upto lintel level. Toilet door frames in granite. Toilets in the flats and penthouses will undergo waterproofing treatment.
- **Plumbing:** Concealed internal plumbing with good quality CP fittings.
- **Water Facility:** Municipal water supply through underground and overhead water tank with borewell backup.
- **Electrification:** Concealed ISI mark copper wiring with suitable MCBs, modular switches and TV, telephone and AC points provided.
- **Terrace:** Open terrace finished with heat and waterproofing treatment, and anti-skid ceramic tiles.

AMENITIES



- Allotted car parking for all apartments.
- 24 hours uninterrupted water supply with R.O. Water Purifier in each apartments.
- Well planned apartment with good natural sun light and air ventilation throughout the day.
- Latest designer digital ceramic tiles and good quality sanitary ware and CP fittings in all bathroom and kitchens of apartments.
- Underground and overhead water tank with sufficient storage capacity for water.
- Underground cabling for wire free look of campus.
- Branded lift with good quality ropes and motor as well as quick service options.
- 24/7 CCTV Security with Security Cabin.
- Video Door Phones in apartments.
- Gated Parking.
- Club House.
- A.C. Gymnasium.
- Indoor Games.
- Multipurpose Hall.
- Garden.
- Jogging Track.
- Children Play Area.
- Swimming Pool.

